

VACUUM SYSTEMS

AUTOVAC

Industrial
Vacuum & Air Systems

Gemini Vacuum System



Piping and muffler
sold separately.

The Gemini Vacuum System consists of two AutoVac vacuum producers and a single filter separator in one convenient package. Choose from six different Gemini models varying in size to serve up to 24 simultaneous users.

The twin vacuum producers create suction to pull air, dirt and debris from the end user's nozzle, through the vacuum hose, and into the lower half

of the filter separator. Here, a precisely engineered cone creates a powerful cyclone that guides debris downward into a waste container. The air then passes through a series of filter bags in the upper portion of the filter separator. Only clean dry air returns to the vacuum producer. Combine your Liberty Vacuum with engineered piping, support structures and motor controls to complete your central vacuum system.

888-628-8682

email: sales@autovacinc.com • www.autovacinc.com

Gemini Vacuum System, 400 Series

Standard 3 Phase	Model: Standard Performance, 3600 RPM*					
	Total Simultaneous Users 15'x1 1/2" Dia. Vac Hose	Dual HP	Vacuum Frame Dimensions	Weight lbs.	Decibels at 10ft.	Separator Dimensions
6-8 Users	10HP 3600 RPM	38"	1400	75	64"x 30"	124-1032
8-10 Users	15HP 3600 RPM	48"	1650	76	64"x 30"	124-1542
10-12 Users	20HP 3600 RPM	48"	1800	77	76"x 30"	124-2052
12-14 Users	25HP 3600 RPM	54"	2100	79	76"x 30"	124-2562

* Please consult your AutoVac sales professional for 50 Hz, 575 volt, and high altitude applications above 3000'. Explosion proof motors available.

To complete your central vacuum system, combine your Gemini with the appropriate piping, motor controls and support structure.

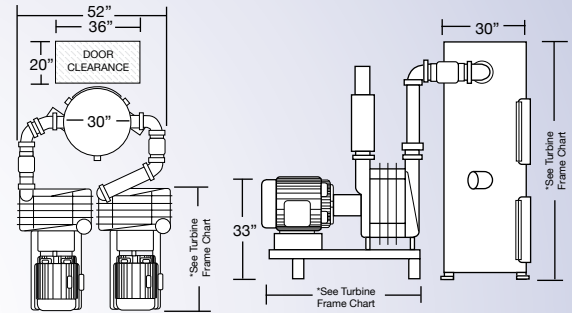

Gemini Vacuum System, 600 Series

Total Simultaneous Users 15'x1 1/2" Dia. Vac Hose	Dual HP	Frame Dimensions	Weight lbs.	Decibels at 10ft.	Separator Dimensions	Order #
16-20 Users	25HP 3600 RPM	60"	2200	81	76"x 30"	126-2562
20-24 Users	30HP 3600 RPM	64"	2300	83	76"x 30"	126-3072

* Please consult your AutoVac sales professional for 50 Hz, 575 volt, and high altitude applications above 3000'. Explosion proof motors available.

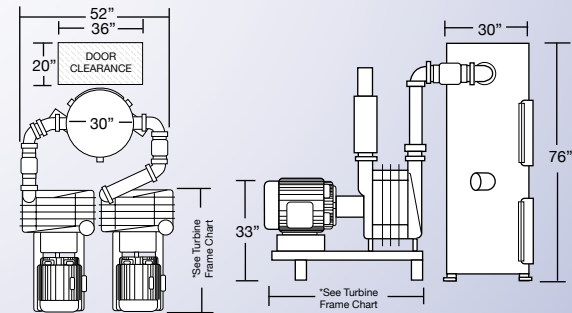

Filter Separator Features

- All metal surfaces of separator are coated with industrial grade primer and automotive grade multi-part urethane top coat.
- Large durable polypropylene dirt bucket is rust-proof and virtually unbreakable.
- Internally glazed polyester filter bags eliminate clogging. No tools needed for fast removal and replacement.
- Leak-proof "U" channel door gasket with sealed air chamber expands and contracts keeping door panel leak-free.
- Lockable door latch assembly.
- 25-year proven design made from heavy grade iron, heavy gauge sheet steel and assembled with continuous welded seams.

Vacuum Producer Features

- Turbine blower casing is housed between two 1/2" thick 356 alloy aluminum head castings for strength, durability and heat dissipation.
- Impellers are dynamically balanced to ensure operation below 1.5 mils at 3,600 RPMs.
- Directional-controlled inlet and outlet air openings accelerate airflow and improve performance.
- Two-bolt outboard flange bearings are self-aligning.
- Extremely durable cast iron TEFC drive motor is aligned at the factory for vibration-free operation.
- SureFit split drive couplings from motor to turbine drive shaft are constructed of durable polyurethane.
- Motors and couplings can be serviced without removing the turbine blower section.
- Sturdy iron rail frame with three point leg design and isolator pads prevent turbine from rocking on uneven mounting surfaces.