

FILTRATION



## Island Pal Separators

Island Pal Separators bring the benefits of AutoVac's filter separators to the point of use. The Island Pal combines centrifugal action with the dust-trapping feature of stocking-type filter bags. The vacuum producer creates suction which pulls air, dirt and debris from the end user's nozzle, through the vacuum hose and into the lower portion of the filter separator. Here, a specially designed cone guides debris downward into a waste container. The air then passes through a series of filter bags contained in the upper portion of the filter separator. A properly sized separator with appropriate filter bags will collect 99.9% at three microns – allowing only clean dry air to pass through the piping system and vacuum producer. This ensures high suction performance and helps eliminate piping failures.



888-628-8682

email: [sales@autovacinc.com](mailto:sales@autovacinc.com) • [www.autovacinc.com](http://www.autovacinc.com)

# Island Pal Separators

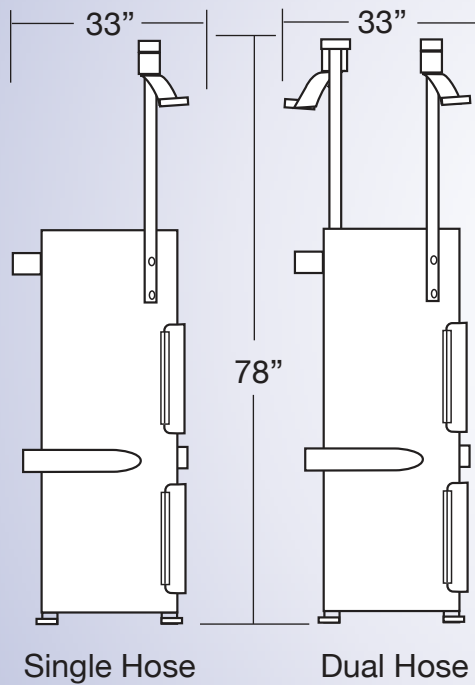

## ISLAND PAL SEPARATORS SINGLE VAC HOSE DROP KIT

Vac Producer Pipe Conn.	Vac System Pipe Conn.	Vac Producer size HP	Const. material	Filter Bag Type	Dirt Container	Protective Coating	Order #
1 ea. 3" pipe to turbine	1 ea. 2" fpt inlet valve	7.5 - 25 horsepower turbines	12 ga. steel	5" self-seal polyester glazed	polypropylene 5 gal.	epoxy primer urethane finish	353-1002

## ISLAND PAL SEPARATORS DUAL VAC HOSE DROP KIT

Vac Producer Pipe Conn.	Vac System Pipe Conn.	Vac Producer size HP	Const. material	Filter Bag Type	Dirt Container	Protective Coating	Order #
1 ea. 3" pipe to turbine	2 ea. 2" fpt inlet valves	7.5 - 25 horsepower turbines	12 ga. steel	5" self-seal polyester glazed	polypropylene 5 gal.	epoxy primer urethane finish	353-1001

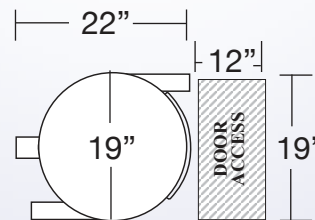

## EQUIPMENT LAYOUT & PIPING CONNECTIONS FILTER SEPARATORS

- This line supplies vacuum suction to Island Pal separator. Hook to vacuum producer inlet connection directly.
- These 2" FPT connections hook to vacuum hose to carry dirt and debris from vacuum cleaning hoses and nozzle.
- 15' x 1 1/2" vacuum cleaning hose with two swivel cuffs.
- Support pipe every 10 ft. minimum with an approved support hanger system. Never allow pipe to sag. Install hangers as needed. Sway brace as required.
- Hold down leg support 3 locations typical.
- Island Pal separator with filter bag section to clean air supply to vacuum producer. Dual hose Model #353-1001.
- Hanger supports hose and nozzle and shuts off vacuum air when nozzle is placed in holder.
- 1 1/2" vacuum nozzle included.
- Support stanchion for hose hanger.
- 2" MPT x 1 1/2" inlet valve and 1 1/2" hose adapter.

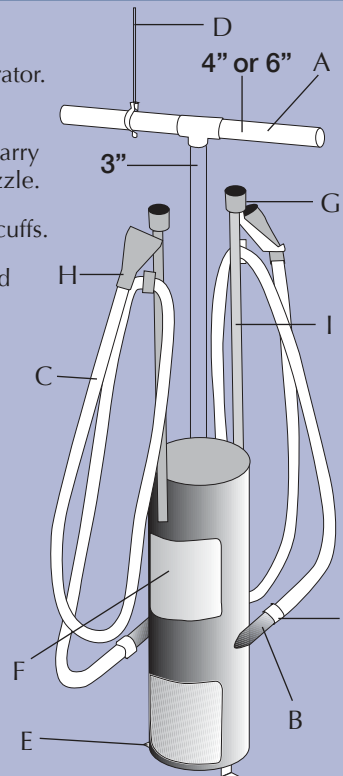

## FEATURES AND BENEFITS

- Large durable polypropylene dirt bucket is virtually unbreakable and rust-proof.
- Internally glazed polyester filter bags eliminate clogging. No tools needed for fast removal and replacement.
- Leak-proof "U" channel door gasket with sealed air chamber expands and contracts keeping door panel leak-free.
- Lockable door latch assembly.
- All metal surfaces of separator are coated with Industrial grade primer and Automotive grade multi-part urethane top coat.
- 25-year proven design made from heavy grade iron, heavy gauge sheet steel and assembled with continuous welded seams.