

VACUUM SYSTEM

AUTOVAC

Industrial
Vacuum & Air Systems

JET PAC

So you're tight on space, but you want the durability and performance of a central vacuum system? Meet AutoVac's **Jet Pac** – a compact, all-in-one industrial vacuum system. It's perfect for operations with single phase power and limited floor space.

The **Jet Pac** provides serious vacuum performance for up to two simultaneous users. Its precision engineered Direct Drive motor is stacked directly above the filter separator. The result is outstanding vacuum performance in a small footprint. And the **Jet Pac** is easy to install and engineered for years of reliable service with very little maintenance.



888-628-8682

email: sales@autovacinc.com • www.autovacinc.com

JET PAC

Single or Three Phase	Model: Standard Performance, 3600 RPM*				
Total Simultaneous Users 15'x1/2" Dia. Vac Hose	Motor	Vacuum Frame Dimensions	Weight lbs.	Decibels at 10ft.	Order #
1 User	1	20"	50	30	C640-0001
2 Users	2	20"	56	30	C640-0021

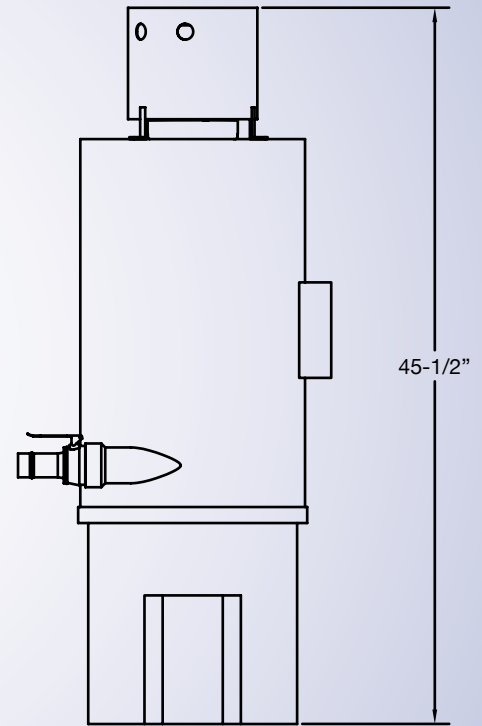
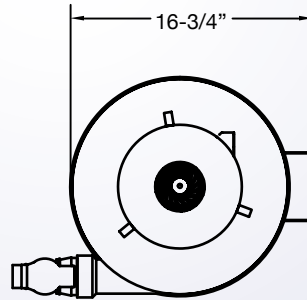

VACUUM SYSTEM LAYOUT AND INFORMATION

ELECTRICAL SECTION



Up to 2 simultaneous users

Electrical Requirements

Single 60Hz

115/230 volts AC

Please consult your AutoVac professional for the following applications:
Canada – 575 Volt customers
For 50Hz • High altitude above 3,000'

FILTER



DEBRIS SECTION



FEATURES AND BENEFITS

CENTRIFUGAL EXHAUSTER

- Jet Pac ships ready to install, simply connect power and secure bolts
- Compact design fits in tight work areas
- Constructed of durable 14 gauge steel with epoxy primer and urethane finish
- Intake and exhaust openings are directional controlled to accelerate airflow and improve suction
- Precision engineered impellers are dynamically balanced using an electronic balance analyzer

FILTRATION & DEBRIS COLLECTION

- Lip seal gaskets provide positive leak-proof seal
- Extremely durable 5-gallon polypropylene dirt container
- Latches on dirt container
- Filter cartridge are internally glazed to prevent clogging
- No tools required to remove or replace filter cartridge

People providing quality and service, working to deserve your business.